

## ► TAPE LAYER TL 2500

*For the application of magnetic stripes and other security features to overlay from web to web or web to sheet. Depending on configuration the TL 2500 Tape Layer can apply up to 12 tapes simultaneously to all industry standard overlay foils. Tape is applied 100% secure to substrate with tape carrier removed and rewound to a single spool for easy disposal.*



Otto Künnecke



CARD BODY  
MANUFACTURING SYSTEMS



Otto Künnecke

*Ideas create solutions*



Otto Künnecke

*Ideas create solutions*

## TAPE LAYER TL 2500

The process produces a high quality "laminated" stripe which today is the bank card standard. Substrate is fed from web, tape(s) are applied with substrate cut to size and delivered to a stack; or alternatively the optional reeling device is available for re-reeling the substrate back to web; suitable for semi-automatic and automatic collation systems i.e. the Otto Künnecke CGM 400 or GM 800 Gathering/Collation Systems.

As standard, the system can apply up to 12 tapes, however the system is also available with a second application station for simultaneous application of up to 24 tapes; i.e. for applications requiring 2 tapes per card.

The standard TL 2500 consists of the following components:

- Foil Infeed
- Up to 12 Application Heads
- Sheet Cutter and Stacking Table
- Touch Screen Control Panel
- Industrial proven heavy duty PLC
- Modem

### ESSENTIAL ADVANTAGES

- Running speed up to 15 m per minute
- Simultaneous application of up to 24 tapes, depending on options
- Efficient high temperature heating system of application heads
- Adjustable cutting length with sheet cutter
- Guide belt for sheet output; vital for thin foils
- Applies all industry standard tapes
- Individual temperature control of each application head
- Small foot print
- Integrated electrical cabinet & control panel

## OTTO KÜNNECKE GMBH

Bülte 1

37603 Holzminden

Germany

Tel. +49 (0) 5531 / 93 00 - 0

Fax +49 (0) 5531 / 93 00 - 903

contact@kuennecke.com

www.kuennecke.com

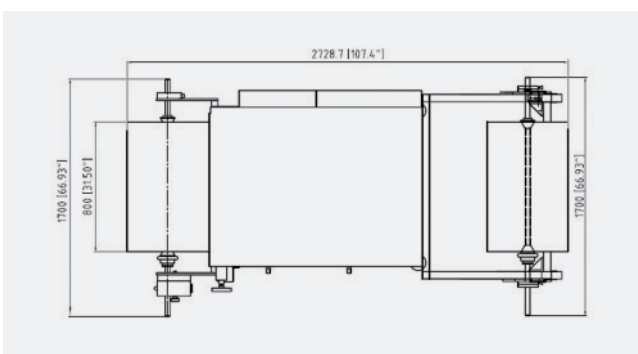

Optional re-reeling device



### Technical Data

Running speed

up to 15 m/min depending on material and release characteristics of tape

Accuracy

± 0.15 mm

Required labour

1 (one) operator

Space requirement

approx. 1.7 x 2.8 x 2.4 m

Subject to technical modifications.